



# CONNECTION DIAGRAM



# DIAGRAMA DE CONEXIÓN

**IGNITION SWITCH** - Signal not fading out during starter work and disappearing immediately after engine stop



**INTERRUPTOR DE ENCENDIDO** - señal no desaparece durante trabajo de arranque y desaparece después de parada del motor

If interface is connected switch is inactive.  
Si interfaz está conectado entonces conmutador está inactivo

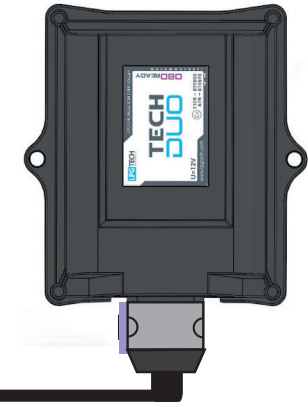

**DIAGNOSTIC CONNECTOR**  
CONECTOR DE DIAGNOSIS

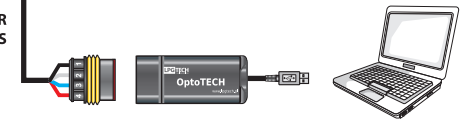

PETROL INJECTORS 1-4  
INYECTORES DE GASOLINA 1-4

GAS INJECTORS 1-4  
INYECTORES DE GAS 1-4

**PETROL/GAS SWITCH**  
CONMUTADOR  
GASOLINA/GAS



PB ECU / ECU DE GASOLINA

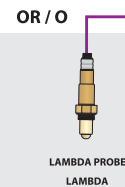
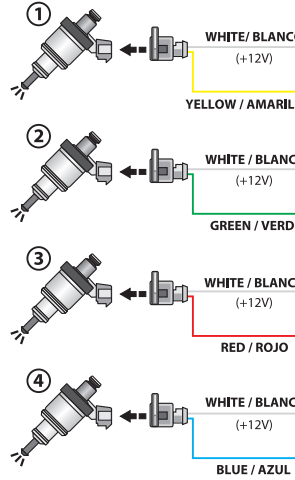
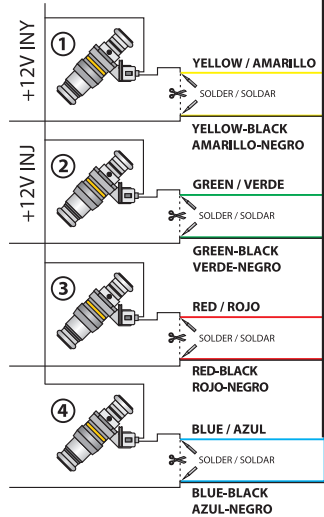

BOBINA DE ENCENDIDO O  
SENSOR DE POSICIÓN  
DEL ÁRBOL DE LEVAS

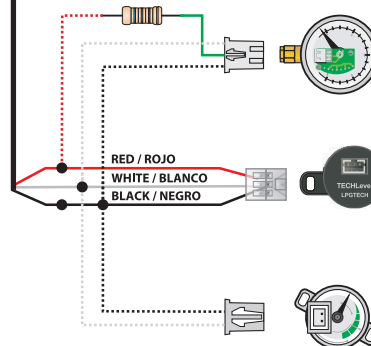
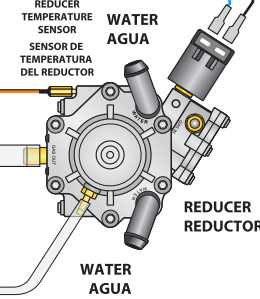
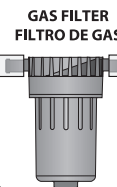
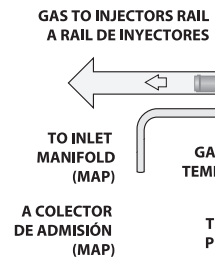
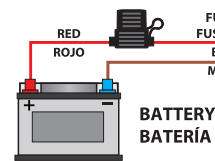

Depending on the manometer type, resistor 680 ohm is required between red and green wire.  
Dependiendo del tipo de manómetro, se requiere resistor de 680ohm entre el cable rojo y verde

